



## JCM Load wireless load shackle With ALRS2 handset

*ALRS2: 'an ever-evolving product'*



Features of our wireless load shackle are:

- Robust anti-rotation
- Load bobbin
- Internal antenna
- Industry leading battery life
- Industry leading wireless range
- No cables
- Excellent accuracy/repeatability
- Capacities 6.5 to 1000 Tonne
- Traceable calibration





**JCM Load Monitoring**  
*'Let us take the load'*

## JCM Load wireless load shackles

Capacity (Te)	A	B	C	D	L	T
6.5	102	52	22	25	84	36
12.5	147	72	32	35	119	51
25	216	103	45	50	146	74
35	238	111	50	57	187	83
55	310	145	65	70	267	105
85	340	162	75	83	260	127
120	428	208	95	95	350	147
150	485	238	105	108	370	169
200	530	279	120	130	470	179
250	565	299	130	140	508	205
300	585	325	140	150	570	205
500	710	298	180	185	636	256
700	810	435	205	217	600	310

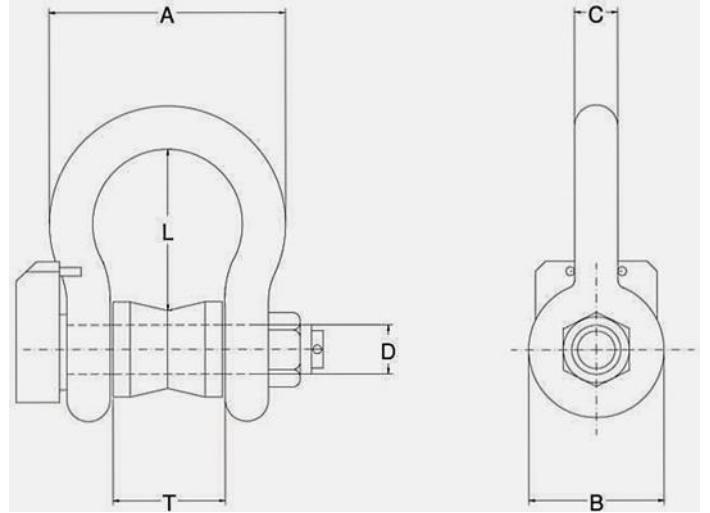

All sizes in mm  
Please confirm any critical dimension before ordering



Units from 2.5 to 50 Tonne are supplied in an IP68 transit case,

75 to 500 Tonne units supplied in a hinged wooden transit crate, made with heat treated wood so ready for international shipping

We are able to supply direct from our factory or via our growing list of sales partners worldwide